

<p>Size 16 up to 350 bar up to 240 L/min</p>	<p>Directional Spool Valve Pilot Operated Type DEH, Series 20</p>	<p>Data Sheet D1003/10.98 GB</p>
--	---	--

Features

- ◇ Modified casing and spool shape to increase pressure flow.
- ◇ Pilot operated by Electro-hydraulics.
- ◇ Selector plug to set Internal or external pilot.
- ◇ Sub-plate mounting.
- ◇ Porting pattern to DIN 24 340 form A ISO 4401 and CETOP-RP 121H.
- ◇ Spring and pressure centred versions to return the valve to the neutral position.
- ◇ Spring or pressure offset versions available.
- ◇ Wet-pin DC or AC solenoids available.
- ◇ Individual electrical connection.
- ◇ Manual override (standard).
- ◇ Optional time shift adjustment.
- ◇ Optional stroke adjustment at the main spool.



Type DEH

<p>Model DEH</p>	<p>Page 1.13</p>	<p>Data Sheet D-1003/10.98</p>	
----------------------	----------------------	------------------------------------	--

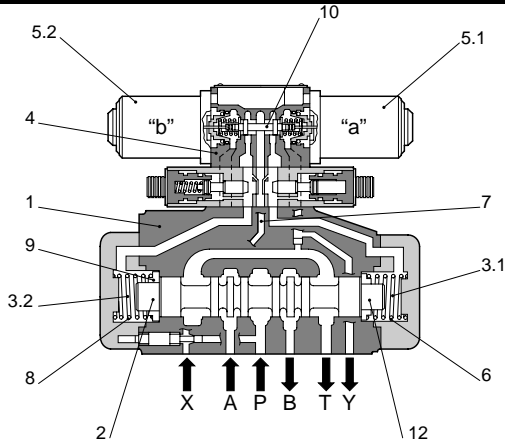

Type DEH 16 4/3-Way Directional Valve with Spring Centring Control Spool

Functional Description

Type DEH Directional Spool Valves are electro-hydraulic pilot operated directional spool valves that are used to control (start, stop and direction) fluid flow.

The valves comprise a housing (1), main control spool (2), one or two return springs (3.1) and (3.2), pilot valve (4) with one or two solenoids "a"(5.1) and/or "b"(5.2).

The main control spool (2) in the valve is held in the neutral or the initial position by the springs.

Initially the two spring chambers (6) and (8) are connected to the tank without pressure via the pilot valve (4). The pilot valve is supplied with fluid via the pilot line (7). The pilot oil supply can be either internal or external (external via port X). When the pilot valve is operated, e.g. solenoid "a", the pilot spool (10) is moved to the left and the spring chamber (6) remains un-pressurised.

The pilot pressure acts on the left side of the main control spool (2) and pushes it against the spring (3.1). Consequently the ports P to B and A to T are connected in the main valve.

When the solenoid is de-energized, the pilot spool returns to its initial position (with the exception of the "detented spool"). The fluid in the spring chamber (8) is unloaded into the tank.

The pilot oil is expelled from the spring chamber via the pilot valve into the Y channel. The pilot oil drain is internal or external (external via port Y).

A manual override permits pilot spool (10) to be operated without energising the solenoid.



Model
DEH

Page
2.13

Data Sheet
D-1003/10.98

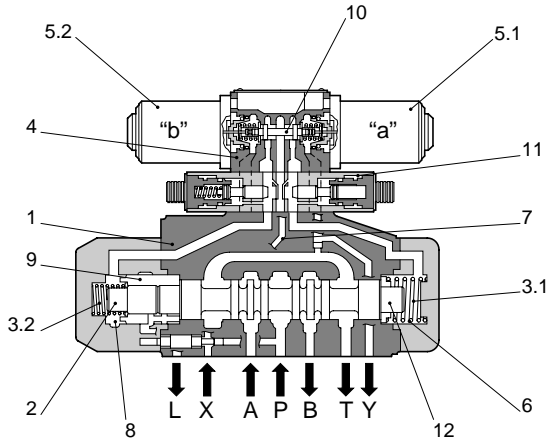

Type DEH 16 4/3-Way Directional Valve with Pressure Centring Main Control Spool

Functional Description (continued)

4/3-Way Directional Valve with Pressure Centring Main Control Spool, Type DEH....2

The main control spool in the main valve is held in the neutral position by pressurisation of the surfaces of spool, centering pin (2) and centering bush (9).

Springs (3.1) and (3.2) hold the main control spool central with no pressure applied.

If solenoid "a" is energised, the pilot spool moves to the left and the chamber (6) is unloaded to the tank, while the chamber (8) remains connected with the control pressure.

The centering bush (9) touches the housing and the centering pin (2) pushes the main control spool to the right until it reaches the stop. When solenoid "a" is de-energised, the pilot spool returns to the central position and the chamber (6) is connected to pressure. The spool surface is larger than the surface of the centering pin (2) and the spool moves to the left until it touches the centering bush (9). The surfaces of the centering bush and pin are larger than the spool and the spool remains in the central position.

If solenoid "b" is energised, the chamber (8) is unloaded to the tank while the chamber (6) remains connected with the control pressure, the main control spool moves to the left until it touches the centering pin (2) at the cover and the centering bush (9) also moves.

When solenoid "b" is de-energised, the chamber (8) is connected to the pressure and the surface of the centering bush (9) and pin (2) under pressure are larger than the spool surface. The spool moves to the right until it touches the centering bush (9) at the housing. The spool surface on the right side is now greater than the surface of the centering pin (2) acting on the left side and the spool remains in the central position.

A drain port is necessary to unload pressure in the chamber between the main spool and the centering bush.



<p>Model DEH</p>	<p>Page 3.13</p>	<p>Data Sheet D-1003/10.98</p>
----------------------	----------------------	------------------------------------

Ordering Code – Type DEH Series 20

DEH 16 P 20 2 05 2 W A 100 AL P08 ET S2 R 10 V

Directional Valve, Electro-Hydraulic Operated

Size
16

Type of Mounting

P: Sub-plate Mounting

Series Number
20

Spool Return

No	Description
2	Spring-offset (2-position) Spring-centre (3-position)
3	Hydraulic-offset (2-position) Pressure-centre (3-position)

Spool Type

For spool type see symbols

Spool Return in Pilot Valve

No	Description
0	No spring return (2-position)
1	No spring return with detent (2-position)
2	Spring-return (2 and 3-position)

Type of Solenoid

W: Wet pin solenoids (with manual overrides)

Electrical Sources

A: Alternating
D: Direct
R: Independent of frequency with built-in rectifier for AC

Voltage

12: 12V D12=DC12V
24: 24V D24=DC24V
100: 100 W100=AC100V 50/60Hz
AC110V 60Hz
200: 200 W200=AC200V 50/60Hz
AC220V 60Hz

In case of R, order in Voltage unrelated with frequency

Suitable Oil

No Code: Mineral Oil
V: Phosphate Ester
W: Fatty Acid Ester,
W1 Water Glycol

Auxiliary Equipment

No code: Without auxiliary equipment
10: Stroke limiter on ends A & B
11: Stroke limiter on end A
12: Stroke limiter on end B

Pressure Reducing Valve

No code: Without reducing valve
R: With reducing valve

Pilot Choke Adjustment

No code: Without pilot choke adjustment
S1: Meter-in pilot choke adjustment
S2: Meter-out pilot choke adjustment

Pilot Oil Supply, Drain Line

Code	Oil Feed	Oil Drain
No code	External	External
E	Internal	External
ET	Internal	Internal
T	External	Internal

Plug-in Throttle in P Port (Pilot Valve)

Code	Function
No code	Without plug-in throttle
P08	0.8mm diameter throttle
P10	1.0mm diameter throttle
P12	1.2mm diameter throttle
P15	0.8mm diameter throttle
P20	2.0mm diameter throttle
P25	0.8mm diameter throttle
P30	3.0mm diameter throttle
P40	4.0mm diameter throttle

Electrical Connections

Code	Function
AL	Central terminal and lamp
B	Angled plug to DIN 43650
C	Large angled plug
CL	Large angled plug with lamp

Model
DEH

Page
4.13

Data Sheet
D-1003/10.98



INTENTIONAL BLANK PAGE

Model DEH	Page 5.13	Data Sheet D-1003/10.98
--------------	--------------	----------------------------



Symbols









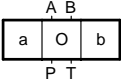
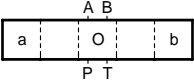
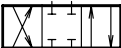
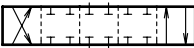
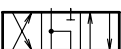
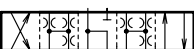
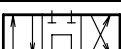
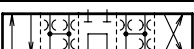

2-Position Valves

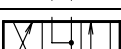
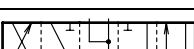
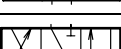
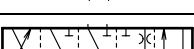
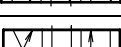
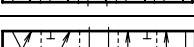
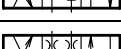
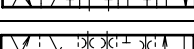
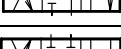
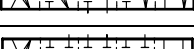
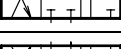
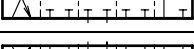
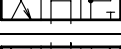
Spool type	Hydraulic symbol	Transient condition
03		
04		
11		
26		

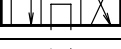

Symbols (continued)

3-Position Valves

Spool type	Hydraulic symbol	Transient condition
		
05		
06		
07		
08		
10		
12		
13		
17		
18		
19		
20		
21		
22		
23		

Model
DEH

Page
7.13

Data Sheet
D-1003/10.98



Technical Data

For applications outside the following parameters, please consult Kawasaki Precision Machinery (UK) Ltd.

Size 16**Operating Pressure, Maximum**

Port P, A, B	350 bar
Port T - Pilot Oil Drain Y External	250 bar
Port T - Pilot Oil Drain Y Internal ¹	160 bar
Port Y - Pilot Oil Drain External	250 bar

Pilot Pressure, Maximum

(With higher pilot pressures, a pressure reducing valve is required)	250 bar
---	---------

Pilot Pressure, Minimum

Pilot Oil Supply X External,	
Pilot Oil Supply X Internal	
(not with Spools 03, 06, 07, 08, 16, 20, 22	
3-Position Valve, Spring-Centred	8 bar
3-Position Valve, Pressure-Centred	8 bar
2-Position Valve, with Spring Offset	10 bar
2-Position Valve, with Hydraulic Offset	5 bar

Hydraulic Fluid

Mineral oil, phosphate ester, fatty acid ester and water glycol. Phosphate ester is only suitable for use with FPM seals.

Fluid Temperature Range

-20°C to +70°C

Viscosity Range

2.8 to 380cSt

Cleanliness

Maximum permissible degree of contamination of fluid is to NAS 1638 class 9. Kawasaki recommend a filter with a minimum retention rate of $\beta_{10} \geq 75$



Model
DEH

Page
8.13

Data Sheet
D-1003/10.98

Technical Data (Continued)

Pilot Oil Volume for Shifting Operation

3-Position Valve, Spring-Centred	4.45 cm ³
2-Position Valve	8.9 cm ³
3-Position Valve, Pressure-Centred:	
from neutral position to shifted position "a"	2.3 cm ³
from shifted position "a" to neutral position	2.15 cm ³
from neutral position to shifted position "b"	4.45 cm ³
from shifted position "b" to neutral position	2.3 cm ³

Pilot Oil Flow for Shortest Shifting Time 27 L/min

Weight

Valve with one Solenoid	8.3 kg
Valve with two Solenoids, Spring-Centred	8.6 kg
Valve with two Solenoids, Pressure-Centred	8.6 kg

Shifting Times¹

¹ Shifting time = Contacting at pilot valve up to start of opening of the control land in the main valve.

Shifting time of valve from neutral position to shifted position with AC (-) and DC (=) operation

~ At Pilot Pressure	AC 50 bar		DC 50 bar		AC 150 bar		DC 150 bar		AC 250 bar		DC 250 bar	
3-Position Valve, Spring-Centred	30 mS		50 mS		25 mS		45 mS		20 mS		40 mS	
2-Position Valve	35 mS		55 mS		30 mS		50 mS		25 mS		45 mS	
3-Position Valve, Solenoid Operated Pressure-Centred	a	b	a	b	a	b	a	b	a	b	a	b
	20 mS	30 mS	40 mS	50 mS	20 mS	25 mS	40 mS	45 mS	20 mS	20 mS	40 mS	40 mS

Shifting time of valve from shifted position to neutral position

3-Position Valve, Spring-Centred	40 mS for AC (-) and 60 mS for DC (=)											
2-Position Valve	35 mS		55 mS		30 mS		50 mS		25 mS		45 mS	
3-Position Valve from Pressure-Centred	a	b	a	b	a	b	a	b	a	b	a	b
	30-40 mS		50-60 mS		25-35 mS		45-55 mS		20-25 mS		40-45 mS	



Model
DEH

Page
9.13

Data Sheet
D-1003/10.98

Characteristic Curves - Type DEH16

Measured at $v = 36\text{cSt}$ and $t = 50^\circ\text{C}$

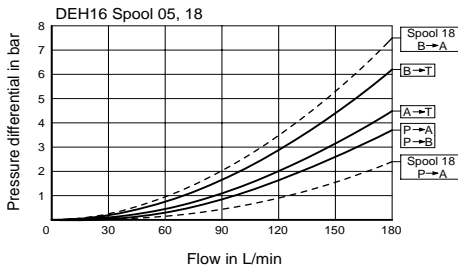
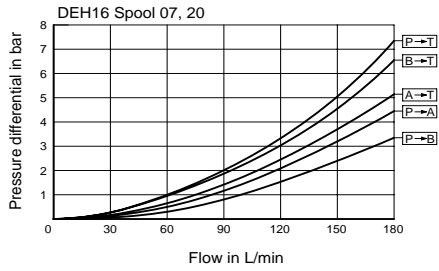
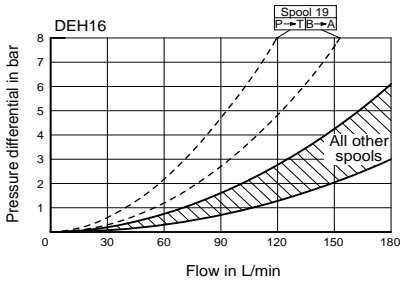

Model
DEH

Page
10.13

Data Sheet
D-1003/10.98

Performance Limits - Type DEH16

Measured at $v = 36\text{cSt}$ and $t = 50^\circ\text{C}$

2-Position Valves, Spring offset 3-Position Valves Spring centred Permissible Flow					
Spool	Operating Pressure - bar				
	70	140	210	280	350
(A) 05, 10, 12, 13, 17, 18, 21, 22, 23, 03, 04, 11, 26	240	240	205	180	170
06	200	145	115	100	90
07, 08, 19, 20	220	160	130	110	100

Notes: The flow values given are achieved when the minimum pilot pressure is present.

In the case of the 2-position hydraulic offset and the 3-position pressure centred, the permissible flow is as shown on the upper line (A), independent of spool type. When the pilot pressure is over 15 bar the flow becomes 240 litres per minute and is independent of spool type and operating pressure.



Model DEH	Page 11.13	Data Sheet D-1003/10.98
--------------	---------------	----------------------------

Unit Dimensions - Type 4DEH16P-20 (dimensions in mm)

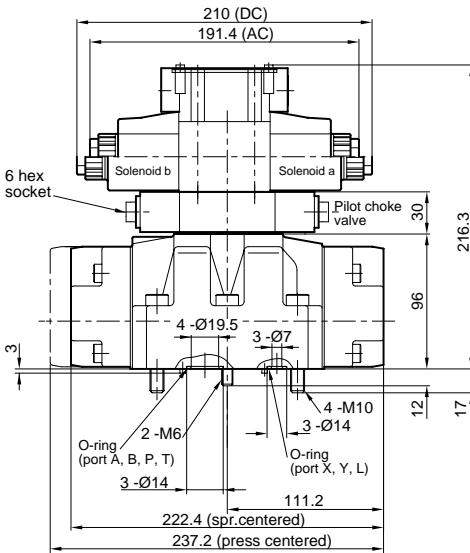
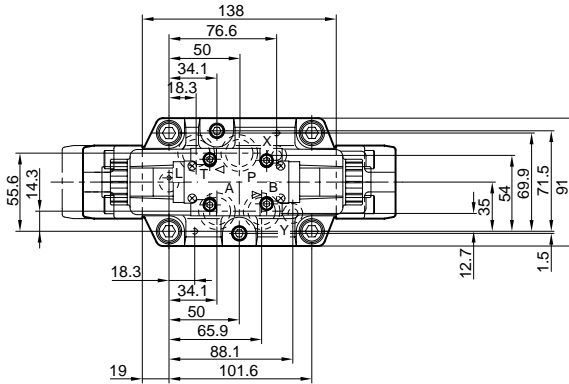

3 POSITION VALVE

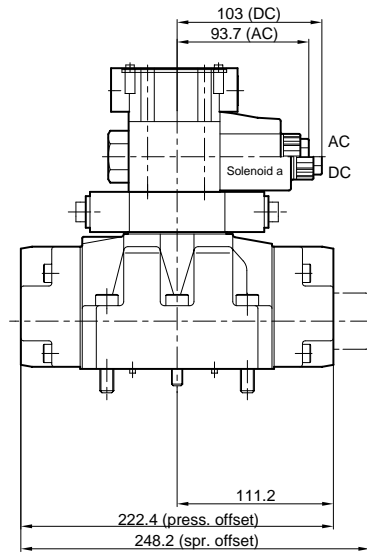

2 POSITION VALVE



Model
DEH

Page
12.13

Data Sheet
D-1003/10.98

Unit Dimensions - Type DEH16P-20 (dimensions in mm) (continued)

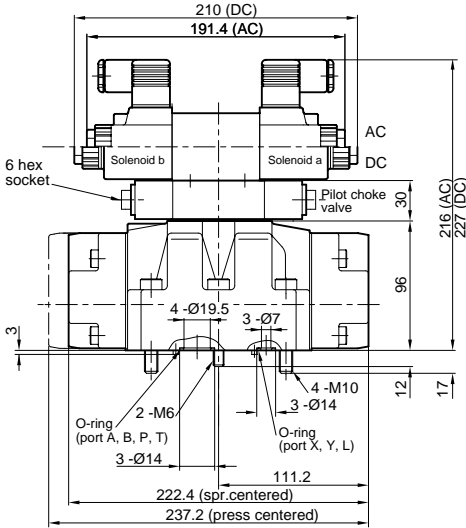
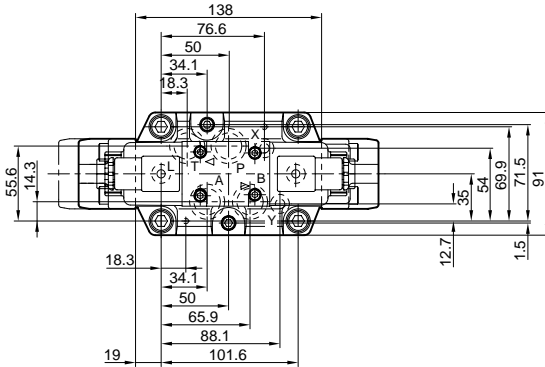

3 POSITION VALVE

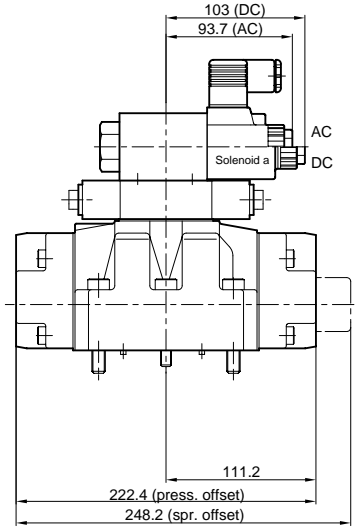

2 POSITION VALVE

KAWASAKI PRECISION MACHINERY (UK) LTD
 Ernesettle, Plymouth, Devon, PL5 2SA, England
 Tel: +44 1752 364394 Fax: +44 1752 364816
 E Mail: info@ kpm-uk.co.uk

The specified data is for product description purposes only and may not be deemed to be guaranteed unless expressly confirmed in the contract

ALL RIGHTS RESERVED, SUBJECT TO REVISION

Model
 DEH

Page
 13.13

Data Sheet
 D-1003/10.98

