

<p>Size 6 & 10 up to 315 bar up to 50 & 80 L/min</p>	<p>Check Valve (Pilot Operated) Sandwich Plate Valve Type S-CH6 & S-CH10, Series 10</p>	<p>Data Sheet S-1002/10.98 GB</p>
--	---	---

Features

- ◇ Pilot operated check valve.
- ◇ Used in vertical stacking assemblies.
- ◇ Leak free closure of one or two actuator ports.
- ◇ Porting pattern to DIN 24 340 form A, ISO 4401 and CETOP-RP 121H.



Type S-CH10

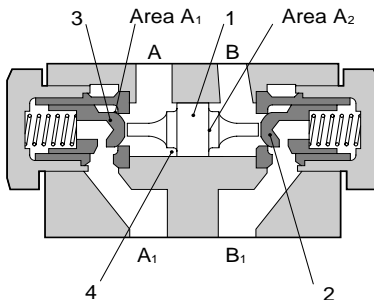

Type S-CH6

Functional Description

Type S-CH6/S-CH10 Series 10 Check Valves are pilot controlled valves of sandwich plate design. The valves provide leakage free closure in one direction for one or two actuator ports and free flow in the other direction. These valves can be used for long standstill periods.

Type S-CH6

The valve basically consists of a housing, a spool (1) and a poppet (2)(3).

When there is no flow through the valve, the poppet (2)(3) is in the closed position. Flow from (A→A₁) acts against the poppet (3) opening the valve, at the same time the spool (1) is pushed to the right and pushes the poppet (2) from its seat and opening B₁→B. Pressure in the opposite direction closes the poppet (3) not allowing the flow. When the flow stops, the poppet (2)(3) returns to the closed position.

To enable the safe closure of poppet the actuator ports of the valve must be connected to the tank when in the centre position.



<p>Model S-CH6 & SCH10</p>	<p>Page 1.6</p>	<p>Data Sheet S-1002/10.98</p>
------------------------------------	---------------------	------------------------------------

Type S-CH10

The valve basically consists of a housing, a spool (1), a ball-poppet (2)(4) and a main poppet (3)(5). When there is no flow through the valve, the ball-poppet (2)(4) and main poppet (3)(5) are in the closed position. Flow from (A→A₁) acts against the ball-poppet (4) and the main poppet (5) opening the valve. At the same time the spool (1) is pushed to the right and pushes the ball-poppet (2) first and then the main poppet (3) from their seats opening B₁→B. When the flow stops, the ball-poppet (2)(4) and the main poppet (3)(5) return to the closed position.

To enable the safe closure of the poppet, the actuator ports of the valve must be connected to the tank when in the centre position.

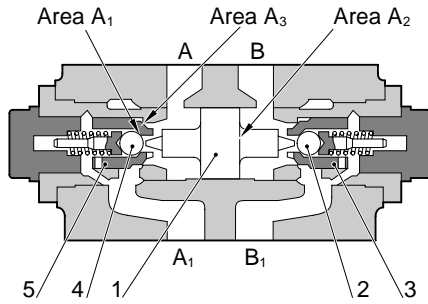

Type S-CH10

Ordering Code – Sandwich Plate Valve

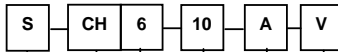

Sandwich Plate Design

Check Valve (Pilot Operated)

CH Leak free closure in one channel
 2CH Leak free closure in two channels

Size
 6, 10

Series Number
 10

Suitable Oil

No Code: Mineral Oil
 V: Phosphate Ester
 W: Fatty Acid Ester, Water Glycol

Leak Free Closure Port

	Code	Port	Free Flow Direction
2CH	No code	Port A	A→A ₁
		Port B	B→B ₁
CH	A	Port A	A→A ₁
	B	Port B	B→B ₁



Symbols

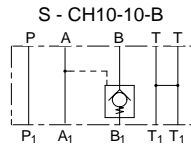
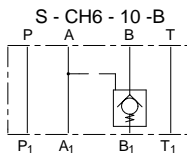
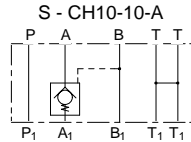
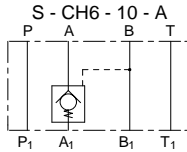
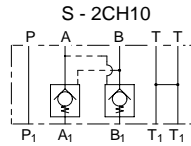
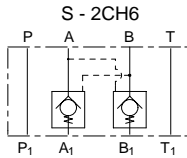

Technical Data

For applications outside the following parameters, please consult Kawasaki Precision Machinery (UK) Ltd.

Maximum Operating Pressure	315 bar
Pressure Fluid	Mineral oil, phosphate ester, fatty acid ester and water glycol. Phosphate ester is only suitable for use with FPM seals.
Pressure Fluid Temperature Range	-20°C to +70°C
Viscosity Range	2.8 to 380cSt
Maximum Flow	50 L/min - S-CH6; 80L/min - S-CH10
Degree of Contamination	Maximum permissible degree of contamination of the fluid is to NAS 1638 Class 9. Kawasaki recommend that a filter with a minimum retention rate of $\beta_{10} \geq 75$ is used.
Opening Pressure in Free Direction	See Characteristic Curves
Direction of Flow	See Symbols
Area Ratio	A1/A2 = 1/3 (size 6 valve) A1/A2=1/10.9 (size 10 valve) A3/A2=1/2.8 (size 10 valve)
Weight	0.9 kg - S-CH6; 2.2 kg - S-CH10



Model S-CH6 & SCH10	Page 3.6	Data Sheet S-1002/10.98
------------------------	-------------	----------------------------

Characteristic Curves

Measured at $v = 36\text{cSt}$ and $t = 50^\circ\text{C}$

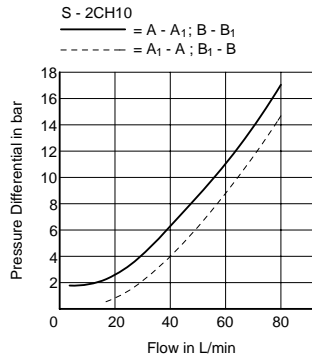
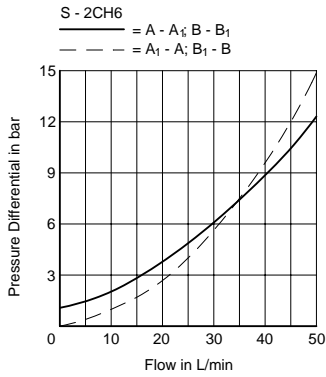

Unit Dimensions (dimensions in mm)(continued)

Type S-CH10

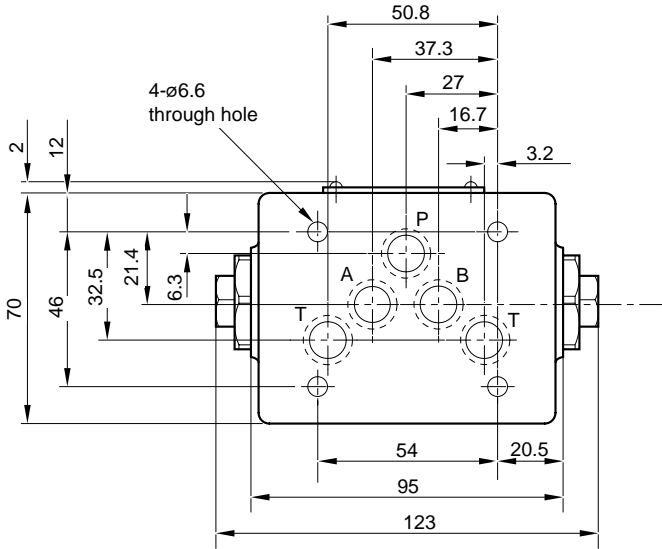

Width across flats 17

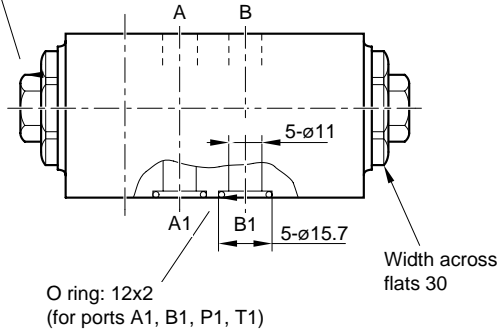
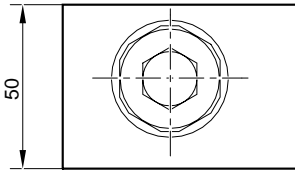

KAWASAKI PRECISION MACHINERY (UK) LTD
Ernesettle, Plymouth, Devon, PL5 2SA, England
Tel: +44 1752 364394 Fax: +44 1752 364816
E Mail: info@kpm-uk.co.uk

The specified data is for product description purposes only and may not be deemed to be guaranteed unless expressly confirmed in the contract

ALL RIGHTS RESERVED, SUBJECT TO REVISION

Model
S-CH6 & SCH10

Page
6.6

Data Sheet
S-1002/10.98

