

<p>Size 10 to 30 up to 315 bar up to 300 L/min</p>	<p>Pressure Reducing Valve Pilot Operated Type PRB, Series 10</p>	<p>Data Sheet R-1004/10.98 GB</p>
--	---	---

Features

- ◇ Compact construction.
- ◇ Large maximum flow volume.
- ◇ Stable pressure control.
- ◇ Suitable for manifold mounting.
- ◇ Two pressure settings.
- ◇ Three adjustment elements.
- ◇ Optional check valve.



Type PRB

Functional Description

Type PRB Series 10 Pressure Reducing Valves are balanced piston, pilot operated type reducing valves that are used to reduce pressure in a hydraulic circuit. Type PRB Series 10 Pressure Reducing Valves will maintain the specified secondary side pressure even when primary side pressure fluctuates.

The valves primarily comprise a main valve (1) with main spool insert (3), and a pilot valve (2) with an adjustment element that facilitates setting system pressures. When not in use, the valve is open, and fluid can flow freely from port A to port B via the main spool insert (3).

When pressure is present in port B, it acts on the bottom side of the main spool, and on the pilot valve (6):

- ◇ Via orifice (4) on the spring loaded side of the main piston (3), and via port (5).
- ◇ Via orifice (7), control line (8), check valve (9) and orifice (10).

According to the spring (11) pressure setting, pressure builds up in front of the valve (6), in port (5) and in the spring chamber (12), holding the spool insert (3) in the open position. Fluid flows freely from port A to port B via the main spool insert (3) until the pressure in port B exceeds the value set at spring (11) when the valve opens. The spool insert (3) now moves to the closed position.

The desired pressure reduction is achieved when the pressure in port B is balanced with the pressure set at the spring (11).

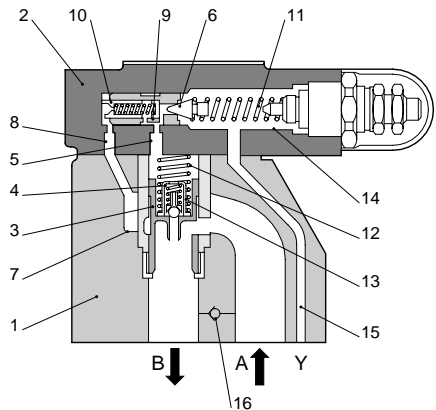

Pilot oil drain from the spring chamber (14) to tank occurs externally via control line (15).

Free return flow from port B can be achieved by fitting a check valve (16).

<p>Model PRB</p>	<p>Page 1.5</p>	<p>Data Sheet R-1004/10.98</p>	
----------------------	---------------------	------------------------------------	--

Ordering Code – Pressure Reducing Valve, Pilot Operated

PRB 10 P 10 1 // 100 Y C V

Pressure Reducing Valve, Pilot Operated

Size
10, 20, 30

Type of Mounting

P: Sub-plate Mounting

Series Number
10

Adjusting Element

- 1: Rotary Knob
- 2: Thread Pin with Hexagon and Protective Cap
- 3: Lockable Rotary Knob

Suitable Oil

No Code: Mineral Oil
V: Phosphate Ester
W: Fatty Acid Ester, Water Glycol

Reverse Free-Flow Check Valve

No Code: Without Reverse Check Valve
C: With Reverse Check Valve

Drain Line

Y: Externally Drained

Maximum Reduced Pressure

100: 100 bar
315: 315 bar

Technical Data

For applications outside the following parameters, please consult Kawasaki Precision Machinery (UK) Ltd.

Weight		PRB 10	PRB 20	PRB 30
Sub-Plate Mounting	PRB*P	3.6 kg	5.5 kg	8.2 kg

Hydraulic

Inlet Pressure, port B Up to 315 bar¹
 Outlet pressure, port A 10 up to 315 bar¹
 Back Pressure, Port Y Up to 315 bar¹
 Setting Pressure Minimum – Q-related, see [Characteristic Curves](#)
 Maximum – Up to 100 bar; up to 315 bar¹

Note: ¹ 315 bar only possible for design without check valve.

Maximum Flow		PRB 10	PRB 20	PRB 30
Sub-plate Mounting	(L/min)	80	200	300

Pressure Fluid Mineral oil, phosphate ester, fatty acid ester and water glycol.
 Phosphate ester is only suitable for use with FPM seals.
 Pressure Fluid Temperature Range - 20°C to +70°C
 Viscosity Range 2.8 to 380cSt
 Degree of Contamination Maximum permissible degree of contamination of fluid is to NAS 1638 Class 9. Kawasaki recommend a filter with a retention rate of $\beta_{10} \geq 75$.



Model PRB	Page 2.5	Data Sheet R-1004/10.98
--------------	-------------	----------------------------

Characteristic Curves

Measure at $v = 36cSt$ and $t = 50^{\circ}C$

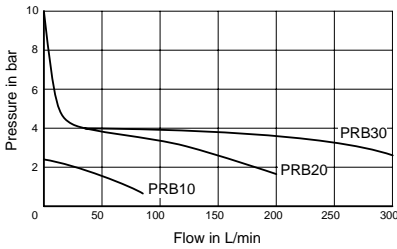

Minimum setting pressure

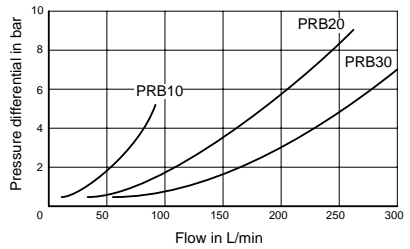

Pressure differential of check valve

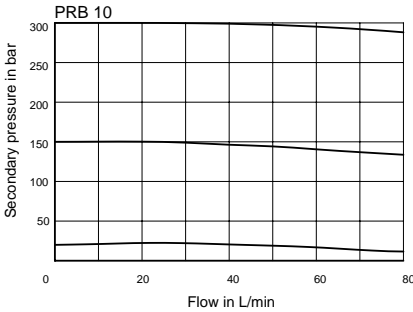

Pressure override

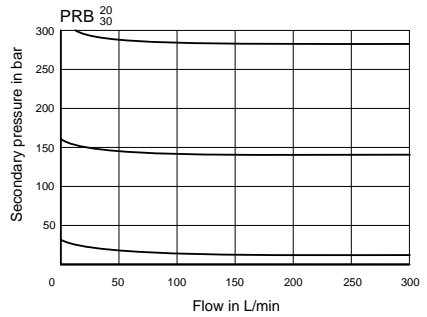

Pressure override



Model
PRB

Page
3.5

Data Sheet
R-1004/10.98

Unit Dimensions – Valve for Sub-plate Mounting (dimensions in mm)

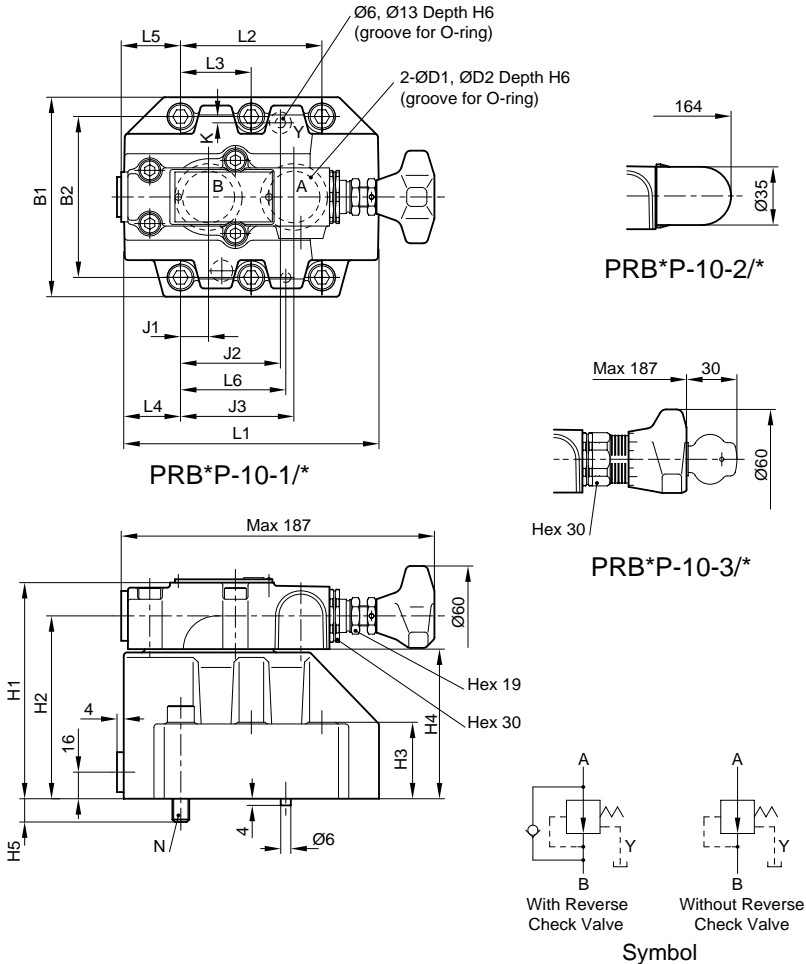

Model PRB

Page 4.5

Data Sheet R-1004/10.98



Unit Dimensions – Valve for Sub-plate Mounting (dimensions in mm) (continued)

Type	B1	B2	N	D1	D2	H1	H2	H3	H4	H5	H6
PRB10	85	66.7	4-M10	15	22	112	92	28	72	12	1.8
PRB20	102	79.4		25	35	122	102	38	82		2.4
PRB30	120	96.8	6-M10	31	40	130	110	46	90	14	

Type	L1	L2	L3	L4	L5	L6	Weight	O-Ring JIS B2401	
								A, B Port	X, Y Port
PRB10	104	42.9	-	35.5	38.5	31.8	3.7 kg	P18, H _S 90	P10, H _S 90
PRB20	121	60.3		33.5	41	44.5	5.6 kg	G30, H _S 90	
PRB30	153	84.2	42.1	34	35.3	62.7	8.4 kg	G35, H _S 90	

Type	J1	J2	J3	K
PRB10	7.2	21.5	35.8	7.9
PRB20	11.1	39.7	49.2	6.4
PRB30	16.7	59.5	67.5	3.8

KAWASAKI PRECISION MACHINERY (UK) LTD
 Ennesettle, Plymouth, Devon, PL5 2SA, England
 Tel: +44 1752 364394 Fax: +44 1752 364816
 E Mail:info@kpm-uk.co.uk

The specified data is for product description purposes only and may not be deemed to be guaranteed unless expressly confirmed in the contract

ALL RIGHTS RESERVED, SUBJECT TO REVISION

Model
PRB

Page
5.5

Data Sheet
R-1004/10.98

