

<p>Sizes 6 &amp; 10 up to 315 bar up to 60 L/min</p>	<p>Pressure Reducing Valve Direct Acting Type PRD, Series 10</p>	<p>Data Sheet R-1003/10.98 GB</p>
--	--	---

**Features**

- ◇ Compact construction.
- ◇ Drain amount minimal compared with balanced piston type, pressure reducing valve.
- ◇ Four pressure ratings.
- ◇ Three adjustment elements.



Type PRD

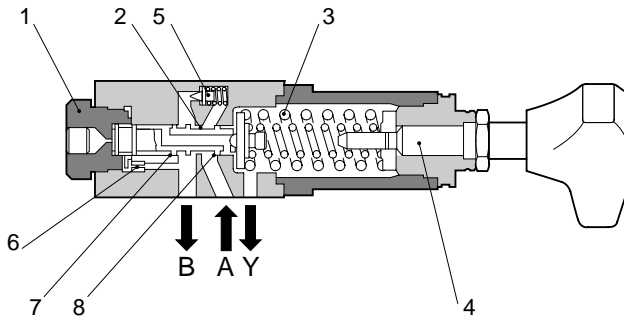

**Functional Description**

Type PRD6P Pressure Reducing Valve is a direct operated valve of the 3-way design, i.e. with pressure relief function on the reduced pressure side.

The valve is used to reduce the pressure on a section of a circuit. Pressure setting is by means of the pressure setting element (4). At rest, the valve is normally open, and fluid can flow unhindered from port A to port B. Pressure in port B is also present on the end of the spool (2), via control line (6), opposing the compression spring (3). When the pressure in port B reaches the pressure level set at spring (3), spool (2) moves to the control position and holds the pressure in port B constant.

Fluid to control the valve is taken from port B via control drilling (6).

If the pressure in port B rises still further due to external forces, the spool (7) is moved still further towards the compression spring (3).

This causes a flow path to be opened over the control land (8) in the control spool (2) to tank. Sufficient fluid then flows to tank to prevent any further rise in pressure.

The spring chamber is drained to tank externally via port Y.

An optional non-return valve (5) is available to allow free flow from port B to A.

A pressure gauge connector (1), permits the 'reduced' pressure to be monitored.

<p>Model PRD</p>	<p>Page 1.5</p>	<p>Data Sheet R-1003/10.98</p>	
----------------------	---------------------	------------------------------------	--

**Symbols**

**Standard Type**

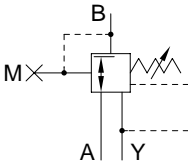

Pilot oil feed internal

Pilot oil drain external without non-return valve

**Model C**

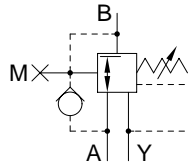

Pilot oil feed internal

Pilot oil drain external with non-return valve

**Ordering Code – Pressure Reducing Valve, Direct Operated**

PRD 6 P 10 1 / 150 Y C V

**Pressure Reducing Valve, Direct Operated**

**Size**  
6, 10

**Type of Mounting**

P: Sub-plate Mounting

**Series Number**  
10

**Adjusting Element**

- 1: Rotary Knob
- 2: Thread Pin with Hexagon and Protective Cap
- 3: Lockable Rotary Knob

**Suitable Oil**

No Code: Mineral Oil  
V: Phosphate Ester  
W: Fatty Acid Ester, Water Glycol

**Reverse Free-Flow Check Valve**

No Code: Without Reverse Check Valve  
C: With Reverse Check Valve

**Drain Line**

Y: Externally drained

**Adjustable Pressure Range (bar)**

Code	Size	
	6	10
25	5 ~ 25	5 ~ 25
75	20 ~ 75	10 ~ 75
150	65 ~ 150	20 ~ 150
210	80 ~ 210	20 ~ 210



**Technical Data**

For applications outside the following parameters, please consult Kawasaki Precision Machinery (UK) Ltd.

Pressure Fluid	Mineral oil, phosphate ester, fatty acid ester and water glycol. Phosphate ester is only suitable for use with FPM seals.
Pressure Fluid Temperature Range	- 20°C to +70°C
Degree of Contamination	Maximum permissible degree of contamination of fluid is to NAS 1638 Class 9. Kawasaki recommend a filter with a retention rate of $\beta_{10} \geq 75$ .
Viscosity Range	2.8 to 380cSt
Maximum Operating Pressure	Size 6 – Up to 315 bar (Port A), up to 210 bar (Port B), up to 60 bar (Port Y).  Size 10 – Up to 15 bar (Port Y).
Maximum Settable Pressure	Up to 25 bar; up to 75 bar; up to 150 bar; and 210 bar
Maximum Flow	Up to 30 L/min (size 6) Up to 45 L/min (size 10)
Weight	Approximately 1.2 kg (size 6), 3.2 kg (size 10)

**Characteristic Curves**

Measure at  $v = 36cSt$  and  $t = 50^\circ C$

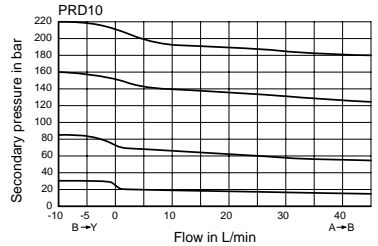
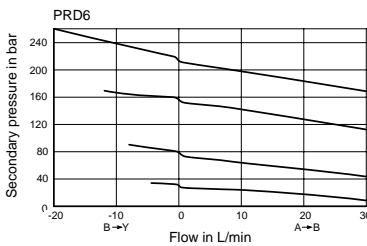
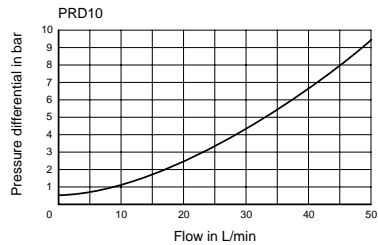
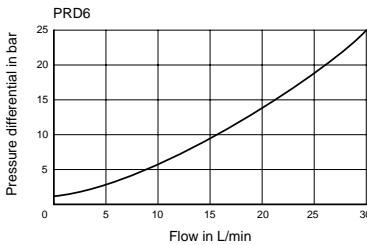

Attention !

The characteristic curves are valid for when the output pressure = zero over the complete flow range.



Model  
PRD

Page  
3.5

Data Sheet  
R-1003/10.98

Unit Dimensions (dimensions in mm) - Valve PRD6P

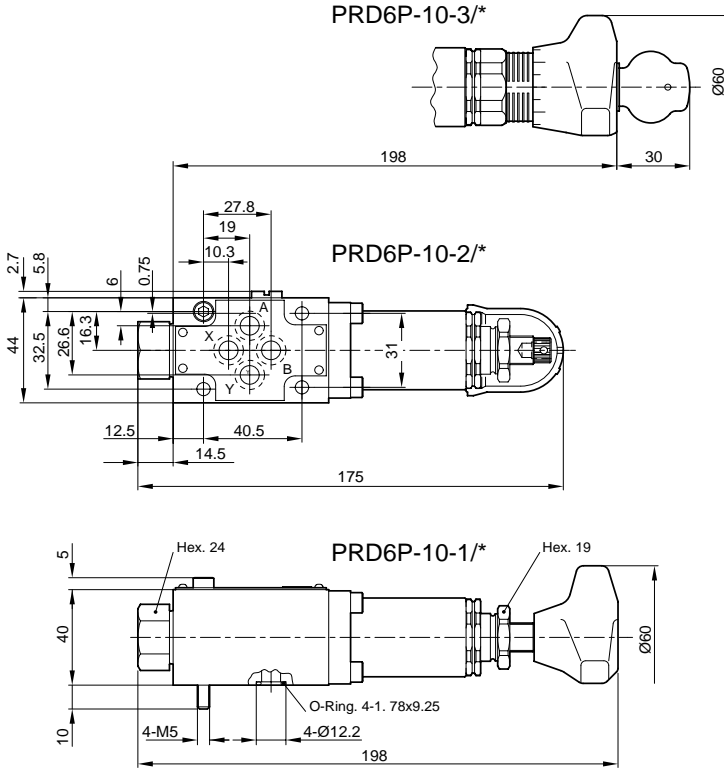

Port position	Ø D	Ø d	t	Remarks
	12.2	7	1.4	AS568 No 012 H <sub>3</sub> 90
		6		
		-		



Model  
PRD

Page  
4.5

Data Sheet  
R-1003/10.98

Unit Dimensions (continued) - Valve PRD10P

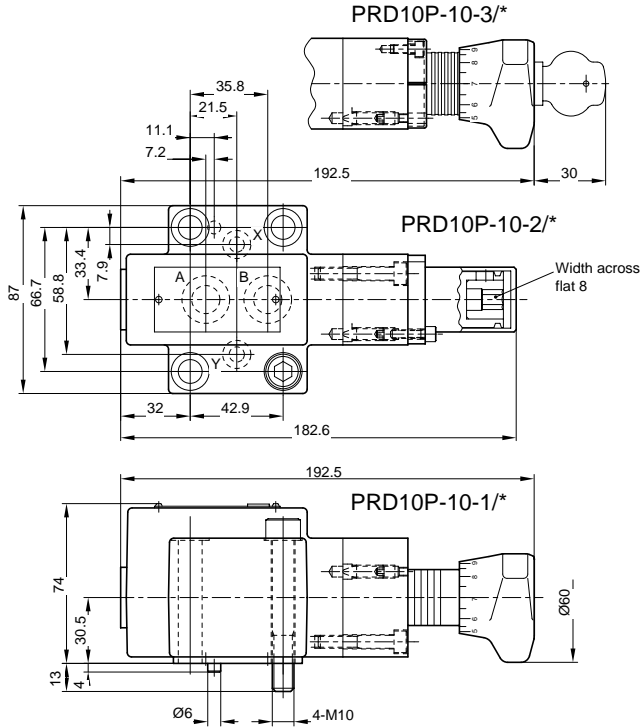

Port position	$\varnothing D$	$\varnothing d$	t	Remarks	
	X, Y	13	7	1.4	JIS B2401 P10 H <sub>s</sub> 90
	A, B	22	13	1.8	JIS B2401 P18 H <sub>s</sub> 90

Since port X is not connected with internal of valve, O-ring is not necessary at port X

KAWASAKI PRECISION MACHINERY (UK) LTD  
 Ernesettle, Plymouth, Devon, PL5 2SA, England  
 Tel: +44 1752 364394 Fax: +44 1752 364816  
 E Mail: info@kpm-uk.co.uk

The specified data is for product description purposes only and may not be deemed to be guaranteed unless expressly confirmed in the contract

ALL RIGHTS RESERVED, SUBJECT TO REVISION

Model  
PRD

Page  
5.5

Data Sheet  
R-1003/10.98

