

<p>Size 5, 10 up to 315 bar up to 50 L/min</p>	<p>Flow Control Valve Two-Way Compensated Type FJC, Series 10</p>	<p>Data Sheet F-1003/10.98 GB</p>
--	---	---

Features

- ◇ Thin blade orifice for accurate temperature compensation.
- ◇ Stroke limiter can be mounted to stop jumping at start up (optional).
- ◇ Check valve (optional).
- ◇ Large selection of maximum flow rates to enable optimum control.
- ◇ Rotary knob with scale.
- ◇ Rotary adjusting knob has a lock to stop accidental adjustment.
- ◇ Porting pattern to DIN 24340, Form A, ISO 4401 and CETROP-RP 121 H.



Functional Description (FJC5P-10-3-10Q-V)

Type FJC Series 10 Flow Control Valves are used to maintain a constant flow independent of pressure and temperature.

The valves primarily comprises a housing (1), a setting element (2), an orifice (3), a pressure compensator (4) and a check valve (5).

Flow from port A to B is passed through throttle orifice (6) which can be varied by turning the setting element (2).

With no flow through the valve, the pressure compensator (4) is kept in the open position by the spring (7).

When the fluid flows through the valve, the pressure at the downstream of the throttle position (3) is applied to the spring chamber of the pressure compensator (4) and the pressure at the upstream is applied to the opposite side.

The pressure compensator (4) moves into the compensating position until the forces balance. As a result the pressure differential between the upstream and the downstream of the throttle position is kept constant, i.e. the flow through the valve is constant.

Flow from Port B to A is passed through the check valve(s) freely.

Type FJC

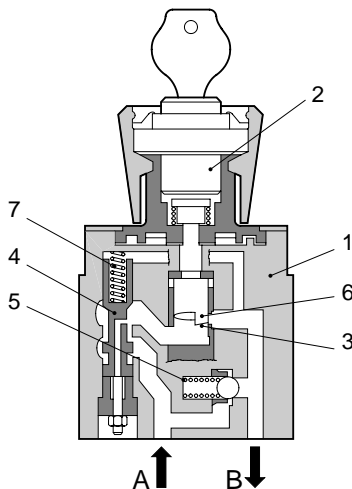

<p>Model FJC</p>	<p>Page 1.6</p>	<p>Data Sheet F-1003/10.98</p>	
----------------------	---------------------	------------------------------------	--

Ordering Code – Flow Control Valve

FJC 10 P 10 3 / 10L J V

Flow Control Valve

Size
5, 10

Type of Mounting

P: Sub-plate Mounting

Series Number
10

Controls

3: Lockable Rotary Knob

Suitable Oil

No Code: Mineral Oil
V: Phosphate Ester
W: Fatty Acid Ester, Water Glycol

Pressure Compensator Stroke Limiter

No Code: Without pressure compensator stroke limiter.
J: With pressure compensator stroke limiter.

Maximum Controlled Flow Capacity

Size	5	10	Max. Flow rate
Code	02Q	-	0.2 L/min
	06Q	-	0.6 L/min
	1Q	-	1.2 L/min
	3Q	-	3 L/min
	6Q	-	6 L/min
	10Q	10L	10 L/min
	15Q	-	10 L/min
	-	16L	16 L/min
	-	25L	25 L/min
	-	50L	50 L/min



Model
FJC

Page
2.6

Data Sheet
F-1003/10.98

Technical Data

For applications outside the following parameters, please consult Kawasaki Precision Machinery (UK) Ltd.

Pressure Fluid Mineral oil, phosphate ester, fatty acid ester and water glycol.
Phosphate ester is only suitable for use with FPM seals.

Pressure Fluid Temperature Range -20°C to +70°C

Ambient Temperature Range -30°C to +50°C

Degree of Contamination Maximum permissible degree of contamination of fluid is to NAS 1638 Class 9. Kawasaki recommend a filter with a retention rate of $\beta_{10} \geq 75$.

Viscosity Range 2.8 to 380cSt

Max. Operating Pressure (port A) 210 bar (size 5)
315 bar (size 10)

Flow for size 5 valve

$q_{V \max}$ l/min	0.2	0.6	1.2	3.0	6.0	10.0	15.0
$q_{V \min}$ (at 210 bar) cm ³ /min	25	30	50	80	100	150	200
Pressure Stability up to $\Delta p=210$ bar	$\pm 2\%$ ($q_{V \max}$)	$\pm 2\%$ ($q_{V \max}$)	$\pm 2\%$ ($q_{V \max}$)	$\pm 2\%$ ($q_{V \max}$)	$\pm 2\%$ ($q_{V \max}$)	$\pm 4\%$ ($q_{V \max}$)	$\pm 4\%$ ($q_{V \max}$)
Minimum Pressure Differential	4 bar	4 bar	4 bar	4 bar	4 bar	8 bar	8 bar

Flow for size 10 valve

$q_{V \max}$ l/min	10	16	25	50
$q_{V \min}$ (at 315 bar) cm ³ /min	150	200	200	300
Pressure Stability up to $\Delta p=315$ bar	$\pm 2\%$ ($q_{V \max}$)	$\pm 2\%$ ($q_{V \max}$)	$\pm 2\%$ ($q_{V \max}$)	$\pm 4\%$ ($q_{V \max}$)
Minimum Pressure Differential	4 bar	4 bar	4 bar	6 bar

Pressure Differential • p for Free Return Flow B to A See [Characteristic Curves](#)

Weight 1.6 kg (size 5)
5.6 kg (size 10)



Model FJC	Page 3.6	Data Sheet F-1003/10.98
--------------	-------------	----------------------------

Characteristic Curves

Measured at $v = 36cSt$ and $t = 50^{\circ}C$

Free flow (B to A)

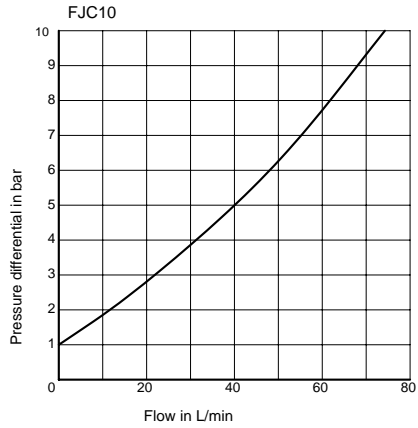
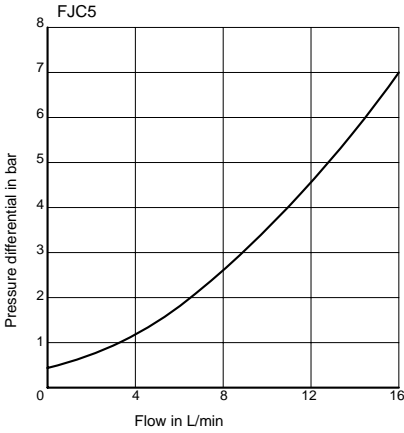

Throttle Setting Characteristic (A to B)

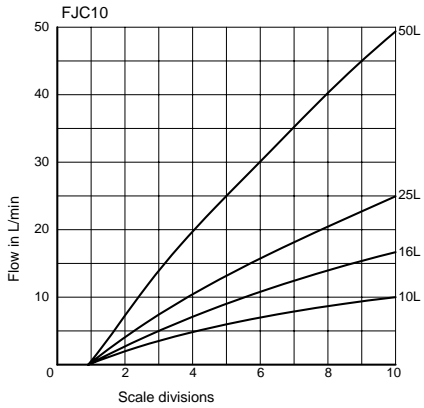
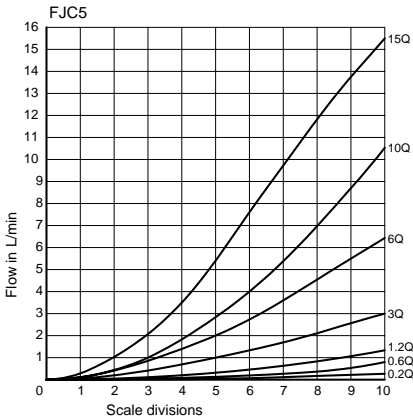

Model
FJC

Page
4.6

Data Sheet
F-1003/10.98

Unit Dimensions Type FJC5P-10-3 (dimensions in mm)

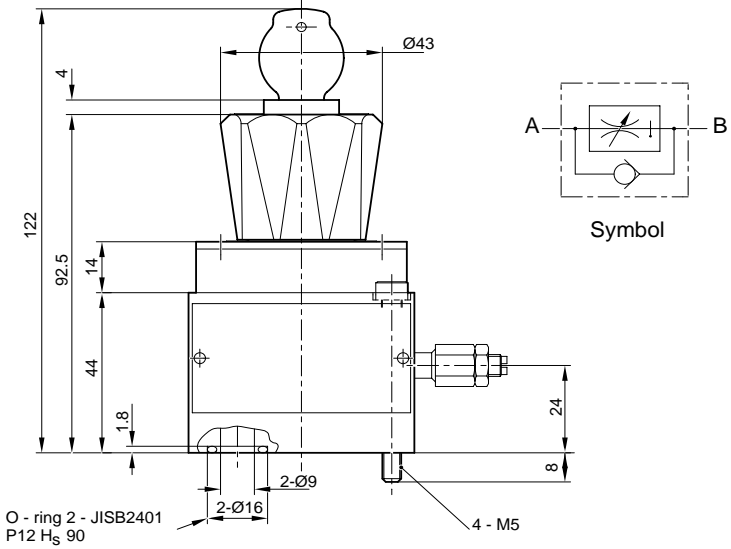
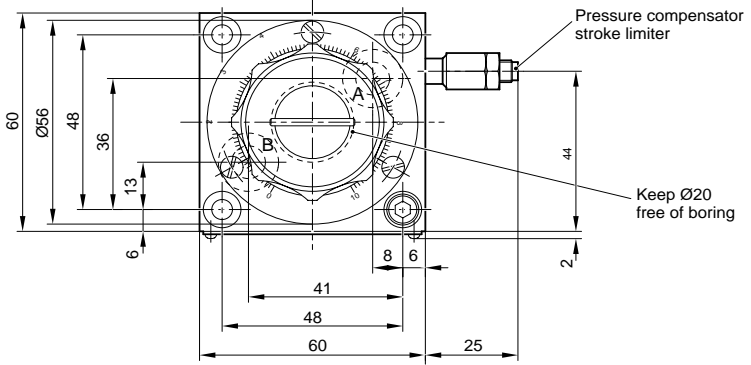

Model
FJC

Page
5.6

Data Sheet
F-1003/10.98



Unit Dimensions Type FJC10P (dimensions in mm)

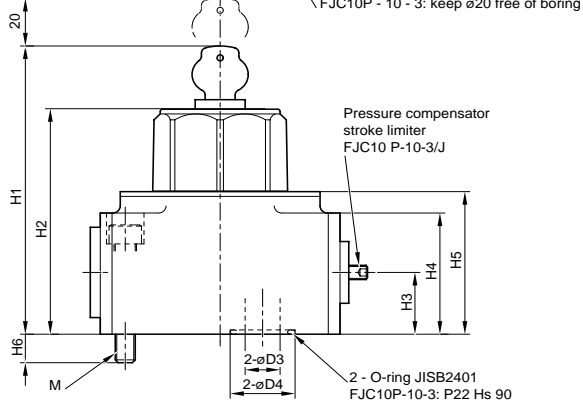
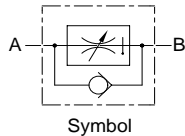
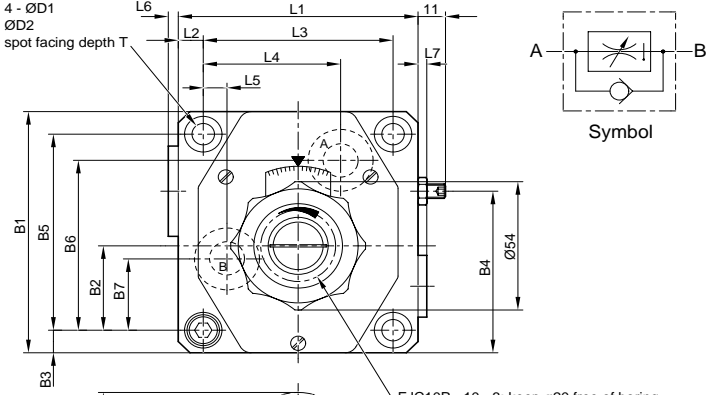

Type	B1	B2	B3	B4	B5	B6	B7	L1	L2	L3	L4	L5	L6	L7
FJC10P-10-3	101.5	35.5	9.5	68	82.5	71.5	30	96	10	76	55	9.5	4	3.5

Type	H1	H2	H3	H4	H5	H6	D1	D2	D3	D4	T	M	Weight
FJC10P-10-3	125	95	26	51	60	12	9	15	14	26	13	M8	6 kg

KAWASAKI PRECISION MACHINERY (UK) LTD
 Emesettle, Plymouth, Devon, PL5 2SA, England
 Tel: +44 1752 364394 Fax: +44 1752 364816
 E Mail: info@kpm-uk.co.uk

The specified data is for product description purposes only and may not be deemed to be guaranteed unless expressly confirmed in the contract

ALL RIGHTS RESERVED, SUBJECT TO REVISION

Model
FJC

Page
6.6

Data Sheet
F-1003/10.98

